

# Tooling

***This chapter sponsored by R.L. Best Company [www.rlbest.com](http://www.rlbest.com)***

This chapter covers the semi-permanent press tooling: **dummy blocks, stems, containers, container liners**, and their repair, maintenance, and lubrication.

## Fixed Dummy Blocks

Most aluminum extrusion presses are now fitted with fixed dummy blocks. They offer several advantages over loose dummy blocks:

- Operator involvement is virtually eliminated.
- Expense and downtime due to a handling system for loose dummy blocks are eliminated.
- Slightly longer billets are possible (typically about 2 inches [50mm] longer).
- Butt disposal is simplified.
- Eliminates damage to front of container from loose dummy blocks.
- Eliminates the risk of extruding without a dummy block or having dummy block fall over in the loader.
- Dead cycle time may usually be reduced.

To successfully apply fixed dummy blocks to your press, several factors must be considered:

**Design of the Fixed Block.** Several proprietary designs for fixed dummy blocks are available on the market today. The design principles have been well described in previous publications<sup>1,2,3,4</sup> and will not be reviewed here. In general, the geometry of the body of the block expands under extrusion load, causing the outer edge to expand practically to the inside diameter of the container. The expansion is caused by pushing the insert into the body of the block. At the end of extrusion, relaxation of press pressure allows the insert to retract and the body to contract in diameter, helping to push the butt away from the face of the block.

Dummy block failure is usually related to the limited elasticity of the steels used and the extreme stresses involved, which tend to expand the block past the steel's creep limits. When the block's outside diameter experiences a permanent increase of 0.020" (0.5mm), permanent loss of elasticity is likely to have occurred. Common problems are the build-up of excessive aluminum on the block, causing high drawback loads and blistering; and wear on the periphery of the block.

Fixed dummy blocks are commonly constructed of alloy H-13 steel, and hardened to Rockwell C 45 - 49.

**Clearance Within the Container.** The diameter of the dummy block must be selected to allow a tight seal to the container during extrusion, and sufficient clearance to pass easily through the container during the return stroke. There is no general agreement on the proper clearance, as it

<sup>1</sup>Castle, Alan F., "Improving Fixed Dummy Block Performance", *Proceedings of 6th International Aluminum Extrusion Technology Seminar*, Vol. I, (1996), p. 301-304.

<sup>2</sup>Bessey, Guy, "Fixed Dummy Block Design", *Proceedings of 4th International Aluminum Extrusion Technology Seminar*, Vol. II, (1988), 131-133.

<sup>3</sup>Castle, Alan F., "Fixed Dummy Block Extrusion", *Proceedings of 4th International Aluminum Extrusion Technology Seminar*, Vol. II, (1988), 134-138.

<sup>4</sup>Robbins, Paul, "Dummy Blocks, Clean Out Blocks, Lubrication and Film Coatings, and Alignment (the Enemy)", presented at AEC Press Maintenance Seminar, (1995), Chicago.

will depend somewhat on the design of the block. Also, poor press alignment will require greater clearance and thus poorer block performance. Recommended clearances between block and container vary: most commonly 0.030" (0.75mm); but 0.4 to 1.0mm (0.016" to 0.040") according to other sources<sup>5</sup>. In fact, most press operators must arrive at the optimum clearance for their situation by trial and error.

**Method of Attachment to the Ram Stem.** Once again, different proprietary designs tend to prevail. The most basic method of attachment is a threaded stud connecting ram stem to dummy block; drawbacks to this design include inflexibility, seizing, difficult changing, and occasional loosening of the block. If the block becomes loose on the stud, the full force of extrusion will come to bear on the stud and will likely break it. Keys and dowels are commonly used to prevent loosening.

A second popular design is the tie bar passing through the stem to a nut at the rear. In this case the base of the block is always in contact with the stem, avoiding excessive loads on the threads.

A proprietary bayonet-type design is said to permit quick change of the block. It is also said to avoid thread damage and to accommodate a small amount of misalignment by permitting some radial movement. (See Figures 3-3 and 3-7)

**Press Alignment.** Alignment of the ram stem and container have been discussed under Chapter 2: Press Alignment. Service life of fixed dummy blocks will be dramatically reduced by poor alignment. Most authorities recommend that misalignment never exceed  $\pm 0.020"$  ( $\pm 0.5\text{mm}$ ).

**Preheating the Dummy Block.** Although the process of extrusion will generate considerable heat, the fixed dummy block still should be preheated before it is placed in service. Preheating will minimize thermal shock and also increase the toughness of the steel, which is higher at press operating temperatures. A recommended temperature is about 600°F (315°C). The block may be preheated in a special oven, or by leaving it in the center of the container for a few hours. However, do not leave the block in any oven for more than a couple of hours, in order to avoid decarburization and loss of temper.

**Lubrication of the Dummy Block and Billet.** This subject has been discussed under **Lubrication of Extrusion Press Tooling – page 3-27**. In general, to eliminate sticking of aluminum to the steel dummy block, lubricant(s) must be applied to the block and/or billet. Most operators lubricate the block by manual or automatic application of water-borne specialty lubes, or manual swabbing of graphite compounds. The ends of pre-cut billets may be painted with specialty lubes or graphite. Sheared billets must be coated after shearing, using flame-generated carbon or spray-applied specialty products such as Boron Nitride.



Figure 3-1: Fixed dummy block  
(Photo courtesy of Castool)

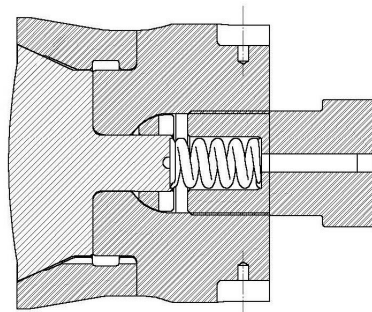

Figure 3-2: Fixed dummy block with replaceable wear ring  
(Illustration courtesy of Castool)

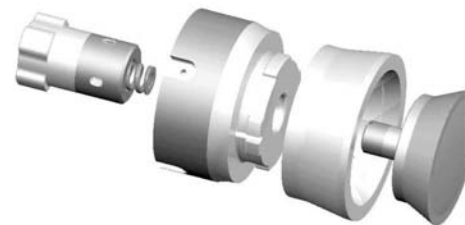

Figure 3-3: Fixed dummy block with bayonet mount and replaceable wear ring  
(Illustration courtesy of Castool)

<sup>5</sup>Castle, Alan F., Ibid.



Figure 3-4: Fixed dummy block for oblong billet  
(Photo courtesy of COMPES)

**Repairing the Fixed Dummy Block.** Replacement is most commonly needed due to wearing of the land area, increase in pick-up during drawback, or loss of elasticity. Castool offers a patented design with a replaceable wear ring.

Worn land areas of dummy blocks may be repaired by welding and re-machining to the original diameter. Castle<sup>6</sup> offers a welding procedure for H-13 blocks:

- Preheat to approximately 400°C (750°F)
- Weld using a gas-shielded arc process (temperature should not fall below 350°C (660°F))
- Slow cool in air to 80°-100°C (175°-212°F) -- *very important!*
- Double temper

**Preventing Dummy Block Damage from the Container Seal Face<sup>7</sup>.** The main cause of stem/dummy block breakage is container shifting caused by a build-up of aluminum on the mating surfaces of the die and container seal face. This area needs to be kept in good condition and free of aluminum.

- Liner ID (inside diameter) may be constricted (coined) from using small dies.
- Dummy block should never completely pass through the exit end of the container.
- Butt shear should cut clean on the die face.
- Acetylene torches and pneumatic tools should never be used to clean the sealing face.
- Container travel should be slowed prior to impacting the die face.
- When a burp cycle is needed, do not open the container, only the ram and seal pressures should be reduced.
- Explosions caused by air and lubricant should be eliminated.

<sup>6</sup>Castle, Alan F., "Fixed Dummy Block Extrusion", *Proceedings of 4th International Aluminum Extrusion Technology Seminar*, Vol. II, (1988), p. 134-138.

<sup>7</sup> From Castool Solutions Bulletin "Fixed Dummy Block."

**Dummy Block Maintenance**<sup>8</sup>. The dummy block should be inspected daily. It should be visually checked for aluminum build-up on the face and land. The land should also be checked for signs of explosions. On blocks with springs, the mandrel should be free and forward from the face of the dummy block. This confirms that the spring is functioning. At the same time, the cap screws securing the bayonet lug and keys should be checked for tightness.

Once each week the dummy block should be removed from the press and cleaned in caustic. It should be visually inspected for wear and accurately measured across the face, the dimension recorded and compared to the original diameter when the block was first delivered. The dummy block will eventually take a set to a larger diameter during use. As the diameter increases, blisters result. Operating life is decreased.

Some sources recommend rotating the block 90-degrees every day to equalize wear, and to lubricate the block internally every week with boron nitride dry powder compound<sup>9</sup>

Machining the dummy block's diameter and/or back face of the mandrel can extend its useful life.

## Loose Dummy Blocks

Where still in use, loose blocks should be regularly checked for aluminum build up; for stress fractures; for nicks and damage due to mechanical problems; and for dimensional tolerances. If blocks show damage, re-check alignment of the billet loader; and inspect the dummy block handling system and repair as needed.

## Cold Clean-out Blocks

The Clean Out Block is used to remove the thin layer of aluminum in the liner when changing alloys.

Regular use of clean-out blocks is recommended for both process reasons and to improve dummy block life. A special block is built to a diameter larger than the dummy block; recommendations range from 0.010" (0.25mm) less than container inside diameter, to 0.030" (0.75mm) larger than the fixed dummy block.

- Cold for dimensional control and safety when handling
- Long to prevent tipping
- Hollow for ease of handling
- Split to prevent damage to the liner
- Double ended to extend life

Frequency of use varies according to the plant, some pushing the clean-out unit once every shift or after alloy changes; and others never using it. A more typical frequency is once weekly.

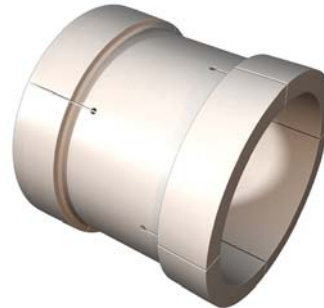
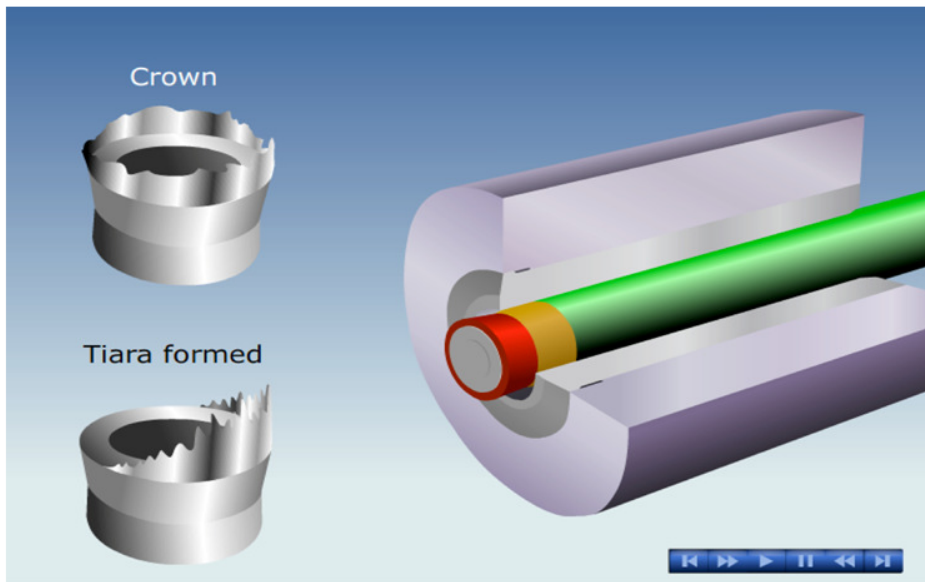

Figure 3-5: Clean-out block  
(Photo courtesy of Castool)

<sup>8</sup> Ibid.

<sup>9</sup>Robbins, Paul; Dixon, Bill; Chien, Ken; and Jowett, Chris; "Today's Understanding of the Function and Benefits of DummyBlock Design," *Proceedings of 11th International Aluminum Extrusion Technology Seminar*, (2016), p.387-404.

## Clean out observations



### Good Maintenance Practice with Cold Clean Out Block:

- Weigh the cold clean-out block
- Load cold clean-out block in billet loader
- Do not shear last die prior to running clean-out block
- Remove die and take to die repair for measurement when cold
- Push cold clean-out block through liner with fixed dummy block
- Remove cold clean-out block and visually inspect for alignment
- Tiara shape means alignment problem stem-to-container
- Crown shape means alignment is good
- Weigh cold clean-out block
- Subtract beginning weight and record salvage aluminum

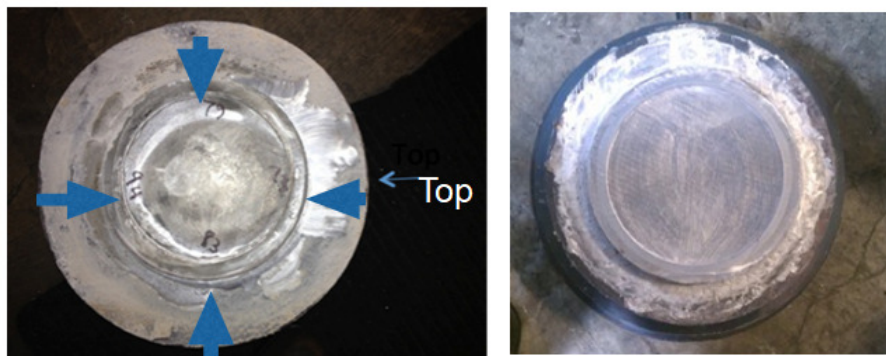

Poorly aligned butt (left) and Properly aligned butt (right)

## Stem

**Function.** The stem (or ram) transmits the compressive forces from the main cylinder to the billet, and so it must operate under compressive stress without bending, breaking, or upsetting.

**Material.** The stem is constructed of hot work tool steels, typically high in chrome, molybdenum, and tungsten, or chrome, vanadium, and molybdenum; A1S1 H-12 or H-13.

**Heat Treatment.** The stem is typically hardened, quenched, and tempered to a hardness range of 429 - 477 Brinell (Rockwell C45-50). As the stem is not normally subjected to extreme temperatures, it is hardened primarily to provide the necessary compressive strength.

**Desired Material Characteristics.** The stem material is chosen to provide very high hardness, high compressive strength, and very low ductility.

**Causes of Damage.** The stem may be damaged by:

**Thermal Shock:** The stem is very sensitive to thermal shock. Heating or cooling the stem too quickly will invite cracking.

**Failure to Preheat:** At room temperature the stem is too stiff and brittle to be used safely. Preheat to 200-400°F (or 100-200°C) before use. Never use direct flame – use a slow soaking furnace to preheat the stem.

**Misalignment:** Any misalignment may greatly increase the stress concentration within the ram and result in bending or breaking. See Chapter 2 - Press Alignment.

**Impact:** Any sudden impact, such as striking the container or malfunction of the dummy block, may cause sharp stresses and eventually weaken the stem. These stresses may be relieved by following the procedure described below.

**Upsetting:** Watch the face of the stem (the face where the fixed dummy block attaches) for upsetting or deformation under load. When the stem diameter increases by 1/8-inch (3mm), or when hairline cracks appear, the stem should be turned down and re-faced.

**Work Hardening:** Continued high-pressure contact with the dummy block may result in formation on the surface of a thin layer of hard metal with many hairline cracks. To prevent these cracks from expanding and propagating into the stem, periodically remove this work-hardened layer and re-face the stem.

**Fatigue:** The stem, like all press components, is subject to fatigue failure in the form of tiny cracks at stress concentration points. To relieve this condition, stress relieve according to the following procedure:

1. Heat the stem to 1000°F (540°C), at a rate no more than 100F° (55C°)<sup>10</sup> per hour.



Figure 3-6: Stem for threaded dummy block attachment (Photo courtesy of Lake Park Tool)



Figure 3-7: Stem for bayonet-type dummy block attachment (Illustration courtesy of Castool)

<sup>10</sup> Note that heating or cooling rate is properly expressed in "Fahrenheit degrees" or "Celsius degrees," which are increments of temperature, as distinct from "degrees Fahrenheit" or "degrees Celsius" which refer to points on a temperature scale.



2. Hold at this temperature for one hour per inch (25 mm) of stem diameter.
3. Remove from furnace and air cool in still air at room temperature.

Frequency of stress relief of the stem should vary according to the history of the stem; suggested intervals for normal conditions:

Compressive Stress - Range of Operation	Suggested Interval for Stress Relief
180,000 - 200,000 psi	20,000 to 30,000 billets
160,000 - 180,000 psi	30,000 to 40,000 billets
130,000 - 160,000 psi	40,000 to 50,000 billets
100,000 - 130,000 psi	50,000 to 60,000 billets
Below 100,000 psi	100,000 billets

**Precautions.** To avoid damage and maximize life of the stem:

1. Preheat the stem before use. A slow heat-up is desirable. Temperatures above 200°F (93°C) are adequate, but the temperature must be achieved through to the center of the stem.
2. Avoid any direct flame impingement.
3. Avoid any water contact (unless anticipated and a special material chosen for this application).
4. Check press alignment through the entire stroke of the ram.
5. Keep the ram clean and correct any visible damage. Re-machine to remove cracks, upsetting, impact scars, or cuts, and stress relieve after each machining.
6. Avoid welding.

**Preventive Maintenance Check List.**

1. Keep the stem dressed at all times. Correct any visible damage as soon as possible by machining to clean metal. Watch for small cracks, upsetting, impact scars, or cuts. Stress relieve the stem after each machining. Never weld the stem.
2. Maintain good press alignment.
3. Check the end of the stem for upsetting, weekly or each time a fixed dummy block is changed.
4. Check the end of the stem for work hardening, weekly or each time a fixed dummy block is changed.
5. Stress relieve when required according to service and keep a record of stress relief.
6. Check its straightness with a straightedge.
7. Check the pressure plate to which the stem is mounted for damage, deflection, or "coining", by using a straightedge and feeler gauges; remove and re-grind flat if damaged. The seat must also be clean.
8. The stem retention ring or other stem mounting devices must be properly tightened.

Check the stem and fixed dummy block often for signs of build-up or excessive wear. Any contact forces are transmitted back to the main cylinder and may result in premature wear of the main ram and bushings, and to the crosshead cylinders as well.

Maintain accurate drawings of all tools, for purchase or repair or replacement of spares.

Inspect spare tools when received (new or repaired) for condition and conformance to dimensions – don't wait until they are needed for use.

Store spare tools in a warm place, to minimize preheat time and avoid thermal shock.

**Note:** Stems are subject to sudden, catastrophic failure. See the photos in Chapter D – **Safety & Environment, Figures D-2 and D-3.**

## Container

**Function.** The container holds and supports the liner to prevent it from breaking under the extreme forces of extrusion. The stress on the liner must be transmitted uniformly to the container, so an accurate shrink fit is required. The shrink fit also induces compressive stresses in the liner, allowing it ultimately to withstand higher stresses. The support must remain uniform and continuous during the extrusion cycle; without it the elastic limit of the liner may be exceeded, causing the liner to fail.

**Material.** The container is a forging, usually chrome-nickel-molybdenum or chrome-molybdenum-vanadium steel, of SAE 4350 or SAE 4150 modified type.

**Heat Treatment.** The container is typically hardened, quenched, and tempered to a hardness range of 280 - 350 Brinell. Draw temperatures over 1000°F (540°C) are used to insure stability at normal operating temperatures; no permanent softening of the container should be experienced during normal service.

**Desired Material Characteristics.** The container material is chosen to provide toughness, high strength, and good ductility when warm.

**Potential Causes of Damage.** The container may be damaged by:

**Thermal Shock:** Any sudden heating or cooling of the container may cause stress cracking or other damage to the container.

**Excessive Heat:** At elevated temperatures, the container material will soften and weaken. At about 1100°F (590°C), permanent softening will occur and the container may become unfit for further use.

**Non-uniform Temperature:** During operation, uneven heat retention may result in a higher temperature near the center of the container. The hotter area will also be weaker and may yield under the pressure of extrusion, causing a “belly” or distortion of the diameter near the center. At lower temperatures (400-600°F/ 200-315°C) this distortion may not be a problem, but at higher temperatures it may become permanent and require re-boring of the container.

**Precautions.** To avoid damage to the container:

1. Preheat the container before use.
2. Heat up slowly – 100F° (55C°)<sup>11</sup> per hour rate of heat-up.
3. Avoid direct flame impingement.
4. Avoid welding. If welding is unavoidable, follow this procedure:

<sup>11</sup> Note that heating or cooling rate is properly expressed in “Fahrenheit degrees” or “Celsius degrees,” which are increments of temperature, as distinct from “degrees Fahrenheit” or “degrees Celsius” which refer to points on a temperature scale.



Figure 3-8: Container cracked through hole for lifting eye. Container was also overheated.  
(Photos courtesy of Lake Park Tool)



Figure 3-9: Alternative “dove tail” design for container lifting.



- Preheat to 1000°F (540°C) before welding
- Weld
- Anneal immediately after welding: heat to 1600°F (870°C), soak, furnace cool, re-heat treat.
- 5. Avoid sudden cooling shocks.
- 6. Operate at the minimum container temperature consistent with good extrusion practices.
- 7. Check thermocouples often.
- 8. Visually inspect the container's keyways periodically for cracks. Cracks found in the bottom radii should be milled or ground to stop their migration into the container body.
- 9. Check the container for signs of relative movement in the container holder and repair as needed.

**Container Preventive Maintenance Check List.**

1. Maintain good press alignment.
2. Check thermocouples at least weekly.
3. Check radii of keyways for cracks each time container is out of the press.
4. Check container hardness each time a new liner is installed.
5. Re-bore each time a new liner is installed.
6. Check for signs of relative movement in the container holder and repair as needed.
7. Check the faces of the container for nicks, scores, or metal build-up; clean and de-burr, and readjust if needed.

***For additional information on Container maintenance, see "Extrusion Container Care and Maintenance" by James M. Pope, page 3-11.***

## Container Liner

**Function.** The container liner resists the abrasive effects of the aluminum and oxides during extrusion. High hardness at elevated temperatures is achieved at the expense of reduced ductility, so the liner must depend on the support of the container to resist breakage.

**Material.** The liner is typically an A1S1 H-12 forging. It is a separate part from the container for increased strength and so that it may be replaced when required by wear or damage.

**Shrink Fit.** The liner is subject to axial loading from friction between the billet and container, so a shrink fit between the liner and container is used to prevent slippage between the components. A shrinkage of 0.24% of the mantle ID is considered the maximum that may be used<sup>12</sup>.

**Heat Treatment.** The container is typically hardened, quenched, and tempered to a hardness range of 400 - 450 Brinell. A minimum of 2 draws is recommended, three where a final hardness in excess of 477 BHN (50 Rc) is required. Each draw should be held at temperature for 2 hours per inch of thickness, to insure proper soak.

**Desired Material Characteristics.** The container liner material is chosen to provide high hardness, low strength, and very low ductility.

**Potential Causes of Damage.** The container liner may be damaged by:

**Thermal Shock:** The liner is very sensitive to any thermal shock. Any sudden or severe heating or cooling of the container may cause breaking.

**Lack of Support:** The liner must be fully supported by the container by means of an accurate shrink fit, or it will fail due to the tensile stresses of extrusion. If the container becomes hotter than the liner, the shrink fit will be lost, resulting in failure.

**Excessive Heat:** At elevated temperatures, the liner material will soften, resulting in premature wear-out. Lower operating temperature will result in longer life and lower costs.

**Precautions.** To avoid damage and maximize liner life:

1. Preheat the liner before use. A long, slow heat-up (100°F/55°C) per hour is recommended.
2. Be sure that the preheat procedure does not result in loss of the shrink fit.
3. Keep the liner warm when the press is not operating. As a minimum, close the ends of the container to prevent cooling; advance the ram so that the dummy block is inside the container bore. During longer delays, an electrical resistance heater should be placed in the bore of the liner and the ends of the container covered.
4. Be sure that the container temperature never exceeds liner temperature enough to result in the loss of the shrink fit.
5. Avoid any direct flame impingement.
6. Avoid any contact with water.
7. Avoid welding.
8. Keep the sealing face clean; avoid any accumulation of dirt, aluminum flash, lubricants, or water.

### Preventive Maintenance Check List.

1. Keep the bore from cooling when the press is not operating.
2. Keep the sealing face clean.
3. Do not operate with a cracked or broken liner.

---

<sup>12</sup> Hahnel, Werner, and Herder, Manfred, "Tool Steel and Design of Modern Containers for Extrusion of Light Metal," *Proceedings of 8th International Aluminum Extrusion Technology Seminar*, (2004)

## Recent Improvements in Container Design

**Container Heating.** In years past, most containers were heated by electric heating elements located outside the container, in the container housing (Figure 3-12). However, the need for more uniform container temperatures as well as improved container life led, some years ago, to development of systems to heat the container from inside the mantle (Figure 3-13). In the case of external heaters, it is possible that the heat source combined with the heat from extrusion may cause the mantle to overheat and become annealed<sup>13</sup> (Figure 3-14).

Another improvement designed to improve temperature uniformity is the change to multiple zones of control. Newer presses often offer 4 or 6 zones of control, divided into 2 or 3 zones axially, as well as separate zones top and bottom (Figure 3-15).

An important requirement is to provide thermocouples for each zone and also for the mantle itself, to prevent over-temperature and annealing.

Note that axial variations in temperature along the liner, caused by heat loss at the container end faces, may result in a higher temperature near the center and result in “bulging” or “barrel” effect.

**Container Cooling.** Most new presses now offer optional cooling of the container liner, by means of passages for compressed air to circulate around the container liner. Air flow is typically controlled by PLC. Combined with multi-zone heating control, PLC controls may maintain liner temperature within a range of 10C° (18F°).

**FEM Analysis** is an essential tool for analyzing the sum of stresses in the container and liner, including thermal stresses. Figure 3-17 illustrates a FEM analysis of a container mantle and liner with cooling, indicating increased stress levels at the cooling grooves. Similar analyses allow design improvements to reduce stress levels and improve container life.



Figure 3-12: Container with external heating elements.



Figure 3-13: Container using heaters inserted into the mantle.

<sup>13</sup> Hahnel, Werner, and Herder, Manfred, Ibid.

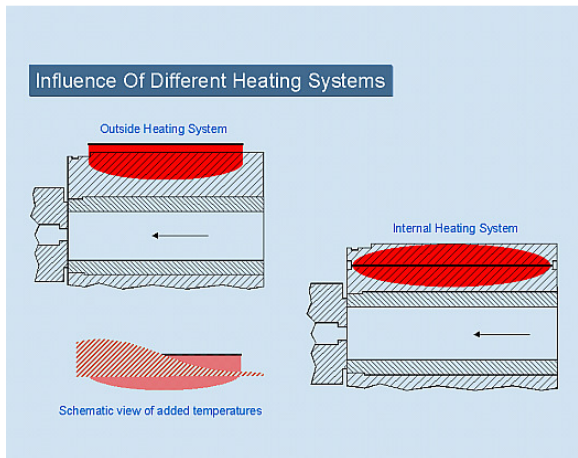

Figure 3-14: Influence of external vs. internal heating systems. (Illustration courtesy of Kind & Co.)

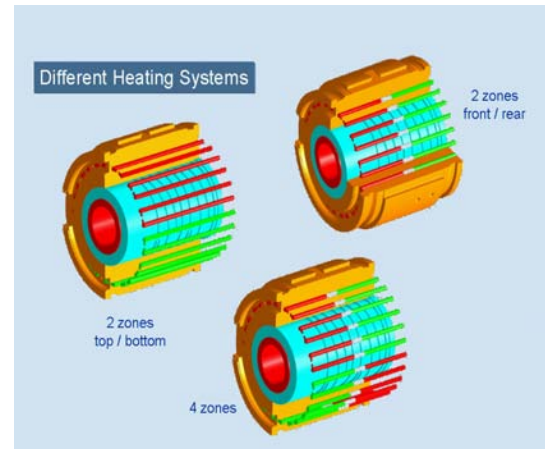

Figure 3-15: Various multi-zone heating systems (Illustration courtesy of Kind & Co.)

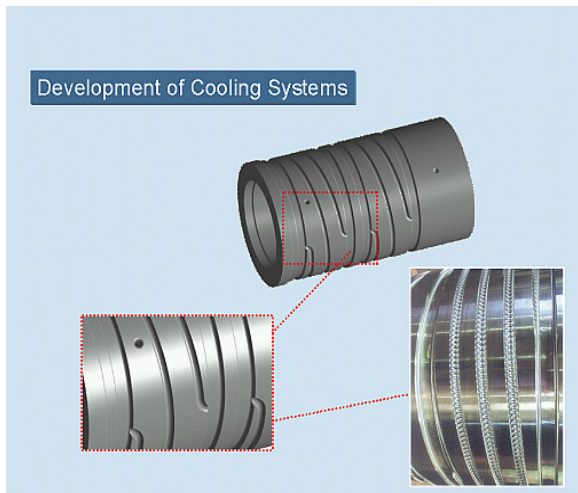

Figure 3-16: Container cooling grooves (Illustration courtesy of Kind & Co.)

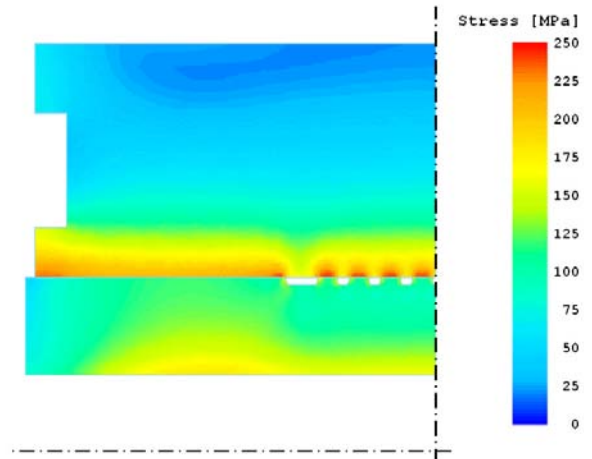

Figure 3-17: Finite element analysis of container during extrusion cycle, with cooling (from Wieser, footnote 11)

Further references on modern improvements in container design are listed in the footnotes<sup>14,15,16</sup>.

<sup>14</sup> Wieser, Volker; Sommitsch, Christof; Haberfellner, Kurt; and Lehofer, Paul; "New Developments in the Design and Production of Container Assemblies," *Proceedings of 8th International Aluminum Extrusion Technology Seminar*, (2004).

<sup>15</sup> Van Dine, Dennis, "Thermal Control of the Extrusion Press Container," *Proceedings of 8th International Aluminum Extrusion Technology Seminar*, (2004)

<sup>16</sup> Robbins, Paul, "Superextruders: Improving Container Life Through Temperature Control," *Light Metal Age Magazine*, April 2003, Page 44.

## Development of a Thermally Stable Container

Research and analysis presented at Extrusion Technology seminar ET16<sup>17</sup> states that “the key requirement of the container and its heating system is that it controls the temperature of the liner within each of up to eight zones, and that it does so rapidly .... (T)he authors argue that the only practical control system is to have multi-zone control with heaters and thermocouple located as near the liner as possible. In addition, the use of cooling channels is then unnecessary, and removal of heat from the liner by conduction to a relatively cool container is preferred.”

By their analysis, heaters on the outside of the container must not only be replaced by heater elements inserted into the mantle of the container, but also must be located close as practical to the liner. This arrangement also results in a more stable extrusion temperature as well as a shorter time to reach stable temperature after a shut-down such as a weekend stoppage.

“The best practice in the event of a relatively short delay is to set each zone to a lower temperature of around 350°C (662°F). To minimize convective losses from the interior of the container liner to the surrounding atmosphere, the stem and dummy block should be inserted approximately 50 percent to 75 percent, and the container closed onto a die set in the die cassette, but not necessarily held with die sealing pressure.”

“When is it appropriate to add cooling to a container? A Well-designed container with optimally developed heat flu gradients ..... plus the use of a higher conductivity steel in the container body, should be able to cope with .... the higher productivity levels in the 6xxx-series alloy extrusion world. In other words, in almost all cases, a modern container can balance heat flow out with excess heat generated in the process, and by thermocouple modulation to control temperature in each of the control zones, and maintain the necessary thermal gradients in the container body.”

“However, there are instances and press lines with specialty products that produce at significantly higher productivity levels, generating more deformation heat, and in need of additional cooling to avoid container and process overheating, and to avoid the need to slow down. A typical example is in high-productivity automotive climate control multi-hole coiled tubing in 3xxx-series or 1xxx-series alloys ....”

### Two-Piece and Three-Piece Multi-Zone Container Designs

“A two-piece container consists of the container body (or mantle) with only the one-piece liner. This simpler design is adequate for most lower-pressure presses, which can generally be defined as those operating at specific pressures of 690MPa (100,000psi) or less, i.e., traditional design presses for conventional 6xxx-series alloy extrusion. When presses operate at higher specific pressures, it is recommended that a three-piece assembly be used, with a sub-liner (often referred to as an outer liner), generally manufactured from 4340 steel, between the container body and inner liner to provide additional support and stiffness, thereby reducing deflection under pressure.”

“In addition, three-piece containers are recommended when presses are used to extrude alloys with lower flow alloys, i.e., 1xxx-series and 3xxx-series alloy groups, and at higher extrusion ratios.... A further situation requiring the use of a three-piece container, and the additional stiffness, is with longer container presses. Containers in excess of 1.2m perform better with a sub-liner.”

After the detailed study reported in this paper, the authors conclude, “4340 is a preferred material with increased toughness and fatigue resistance, therefore better able to accommodate the applied stress levels and cyclical loading conditions in a container body. The 4340 has the added benefit of higher thermal conductivity at 42W/m<sup>2</sup>K .... therefore is better capable of quickly developing stable thermal gradients, and better able to conduct heat from the critical deformation zone inside the container during extrusion.”

---

<sup>17</sup> Chien, Ken; Dixon, Bill; Robbins, Paul; and Jowett, Chris; “The Design and Benefits of a Thermally Stable Container,” *Proceedings of 11th International Aluminum Extrusion Technology Seminar*, (2016), p.427-450.

Following are a few selected images and recommendations from a presentation by Dan Dunn of Castool about extrusion containers, from the AEC Press Maintenance Workshop, Atlanta, April 17, 2018. For details contact [Dan.Dunn@castool.com](mailto:Dan.Dunn@castool.com)

As related in this chapter, page C-12, location of container heaters is critical to proper temperature control:

### Comparison of Different Container Designs

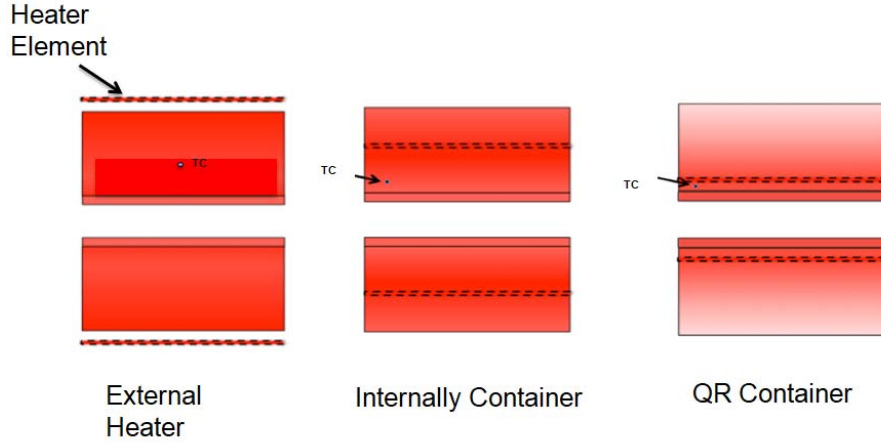

Heaters internal to container (left) and located close to liner (right)

#### Before and After Comparison Thermal Imaging

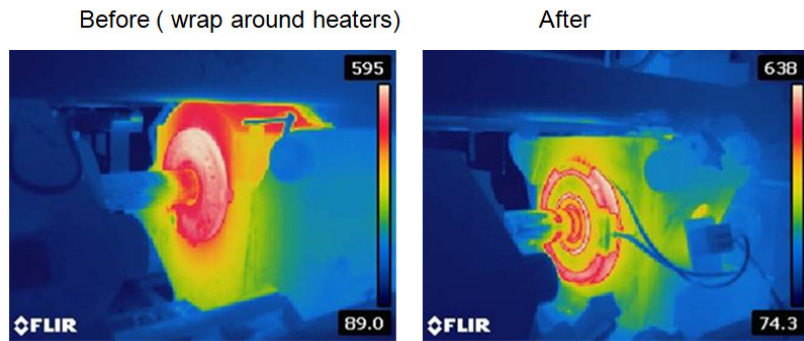

Infrared images with external heaters (left) and heaters near liner (right)



## Various Heating Phases of Standard Container

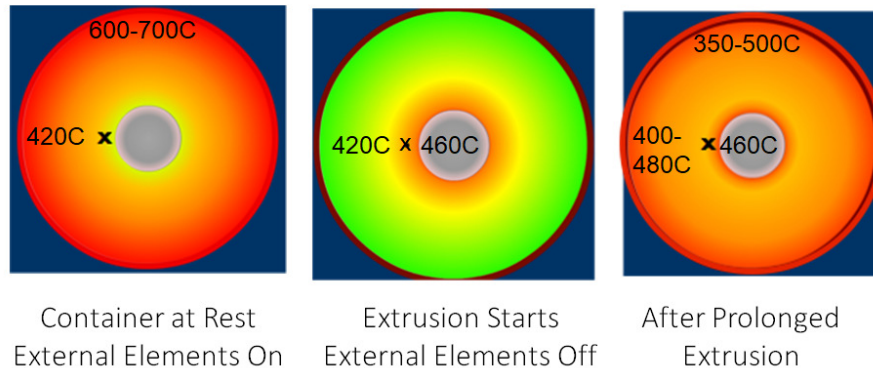

## Effect of Container on Billet Skin Flow

**Billet skin is rich in Fe, Si and Mg – it anodizes differently and melts at different temp.**

- Direct inflow ends up in surface (a)
- Back-flow at the end of press ends up in centre of section (b)

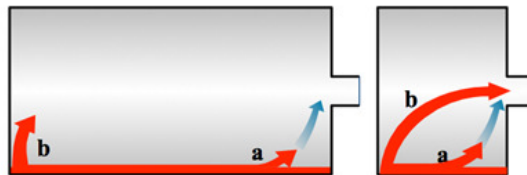

- Use quality billets with thin shell zone layer
- Get the temp. of the container right to limit type (a) inflow
- If container is too hot you get a lot more type (a) inflow = bad surface
- If container is too cold you get more type (b) inflow (coring)
- If container is unstable you get..... Just about anything

49

### Storage of Cartridge Heated Containers

When not in use Cartridge heated containers should be stored in a dry environment with minimal or no humidity. At no time should the container be stored outdoors in the rain or shipped without proper covering to keep the electrical system dry.

Prior to applying power to the container a megohm test should be completed to verify it is safe to apply full power to the container.

A frequent problem in regards to cartridge heaters that use MgO (magnesium oxide) as an insulator is they may develop a low megohm or insulation resistance. While MgO is compressed to a rock hard state and has excellent dielectric properties when dry, it is still able to absorb and retain moisture from the atmosphere. This hygroscopic nature of MgO can result in high leakage

currents when elements have not been energized for long periods of time. It is therefore recommended that elements or assemblies that have a low megohm reading less than 0.25 megohms (250,000 ohms) be dried out before use. Although electric heating elements have been safely energized with virtually no insulation resistance it is highly recommended that proper insulation resistance be restored to eliminate any possible damage to the heater or safety hazard to personnel. It is recommended to insure proper wiring and grounding of the system in accordance with the National Electrical Code and other state and local regulatory agencies.

### **Drying the Elements**

A simple and practical method of drying the elements is to preheat the container in an oven at 350 °F / 175 °C for approximately 12 hours or until satisfactory megohm readings have been restored.

Measured readings of 1000 times the rated voltage indicate safe energizing at full power. For example a 480 volt heater should read 480,000 ohms to ground using the 500Vdc or 1000Vdc setting on a high range ohmmeter(megger).

### **Wiring Protection**

Contaminants such as oil, abrasive or spray can enter the unsealed element and deteriorate insulation. Care should be taken to keep the electrical channel housing and electrical system as dry as possible and free of contaminants.

If the container is operating within specification, the cover plate should not be removed.

Resistance and current readings can be taken at the wiring connections on the container and the main power junction box.

### **Recommended Spare Parts**

- Elements (long delivery time)
- Thermocouples
- Solid State Relays

*Editor's Note: The following paper was presented by Jim Pope, Special Projects Consultant to Lake Park Tool:*

## **Extrusion Container Care and Maintenance**

by James M. Pope

Presentation at AEC Press Maintenance Workshop, Chicago, Illinois May 1<sup>st</sup>, 2002

**Introduction.** For those of you who work in an extrusion plant, that big hunk of steel referred to as "the press" appears to simply sit there and effortlessly produce extrusions. To the contrary, however, this machine is doing tremendous work, and very high stresses are being induced in all the major components. During every push the tie rods are stretching, the main cylinder is bowing and elongating, the front platen is bending, the stem is being compressed, and the container liner assembly is subject to very high hoop stress forces. In this presentation we are going to examine the container-liner assembly and how to obtain the maximum life from it.

Container-liner assemblies are considered expendable tooling and are therefore expected to have a finite service life. Unfortunately they are also one of the most abused parts of an extrusion press. Excluding the dies they are the only part of the press that has to do its work at a constantly elevated temperature. The stem also gets hot, but it is normally half the temperature of the container. Due to the combination of high stresses and heat under which it must perform it is imperative that certain procedures be observed in order to get the maximum possible life out of your container-liner assemblies.

Following are the most common causes of premature container or liner damage and failure:

- Improper pre-heating
- Over-heating
- Fatigue cracks
- Misalignment between the stem and the container
- Misalignment of the press frame (tie rods)
- Insufficient bearing area between the die and the liner face
- Aluminum buildup on the face of the die
- Caved platen pressure ring or caved platen

**Pre-heating.** Let us start with a review of the proper pre-heat procedures for a new or cold container. The most preferred way to pre-heat a container is in a dedicated pre-heat oven with accurate temperature controls. Lacking this piece of equipment some extruders use their aging oven or die pre-heat oven. When using an extrusion aging oven for pre-heating, the container can only be brought up to 400 to 450°F (200 to 230°C). The remainder of the heating process will have to be done in the press.

During pre-heating the container should be brought up to extrusion temperature of 700 to 800°F (370 to 425°C) in increments of 100°F (55°C). It is recommended to allow a 15 minute minimum soaking time between raising the temperature increments when the container is below 400°F (200°C). Once it is above 400°F (200°C) the soaking time should be 30 minutes between raising the temperature increments. The container should have a thermocouple inserted in it to verify the temperature. If the container is being pre-heated in the press there should be a minimum of two thermocouples used, one to read the internal temperature at the liner and another to read the temperature of the outside diameter. It is important to monitor the outside diameter temperature in order to not over heat and anneal the container. If a bore heater is being used in tandem with the press heaters, care should be taken to balance the heating between the two systems. A bore heater should never be used as the only source of pre-heating a container as there is a great risk of splitting the liner and container. A container should never be put into production under 650°F (340°C) with 700°F (370°C) being the recommended minimum.

**Over heating.** Evidence of over heating is scaling or erosion of the container outside diameter. In most instances of over heating the container has also lost its proper hardness. In extreme cases the entire container will be bowed.

Annealing of steel is a basic function of time versus temperature. The annealing temperature for H-12 and H-13 steels starts at 1100 °F (590°C). However prolonged use at lower temperatures has the same effect. Therefore it is of utmost importance to limit the temperature of containers to 750°F (400°C) or less. Overheating can usually be attributed to inadequate temperature controls or in some cases failed controls. Very few presses built prior to the late 1980's had more than a single thermocouple to monitor the container temperature. Due to increasing complaints about short container life, the press builders began to install a second thermocouple to monitor the temperature on the outside of the container. This controller was normally set at 900 to 950°F (480 to 510°C) and would shut off the container heating system if the container reached this temperature. If your press does not have an over-temperature protection thermocouple one should be installed as soon as possible.

Today all new presses are being built with four to six zones of temperature controls. Another feature now being used in containers is air cooling of the liner in the front half next to the die. This is being done as a production enhancement, however it has also contributed to keeping the container in the desired temperature range. The zone heating and liner cooling are also features that are now being incorporated into retrofit packages for older presses.

**Fatigue Cracks.** Cracking begins to occur in containers that have been in service long enough to begin to lose their hardness. Most cracks start to show in keyways and this is due to several factors. A loss of hardness is the most common reason and this is due to over heating. Another reason is improper machining. No sharp corners should exist in internal corners. They should be machined with at least a .125 inch (0.30mm) radius. Sometimes the container design can be modified to eliminate keyways being cut the entire length of the container. If cracks start to show up around lift holes or thermocouple holes this again is usually due to a loss of hardness and the resultant bowing. Once cracking has started to occur, the container's useful life is basically over.

**Misalignment Between the Stem and the Container.** Some 15 to 20 years ago, before widespread use of fixed dummy blocks, container alignment was not a real critical component of extrusion press operation. As long as the container was close to being centered on the die and the billet would go into the liner bore and the stem was close to being in line with the liner bore, this was good enough as the loose dummy blocks of that era had excellent self aligning properties. Today, with almost universal use of fixed dummy blocks, accurate container alignment is critical to the operation of an extrusion press. Some fixed dummy blocks are designed to float or adjust for small amounts of misalignment. However the ability for dummy block self alignment should not be an excuse for not having precise guiding of the container and good alignment adjustment capability. Misalignment between the fixed dummy block and the liner bore can cause chips to be cut out of the entry end of the liner face. Longitudinal score lines on the inside of the liner bore are also an indication of the container bore not being concentric with the press centerline.



Figure 3-10: Container with crack through keyway, probably caused by overheating. A larger radius may help eliminate this problem

*(Photos courtesy of Lake Park Tool)*

**Misalignment of the Press Tie Rods.** If the tie rods have lost their pre-stress or the cylinder and front platens are out of tram this could cause the container to shift away from the press centerline during extrusion. This condition would cause longitudinal scoring inside the liner bore. This condition cannot be detected by simply checking the clearances between the stem and liner bore when the press is at rest as the container shifts out of alignment only after pressure has been applied. A pre-stress and tram check of the press is required to find and correct this problem.

**Insufficient Bearing Area Between the Die and Liner Face.** To prevent flashing of the aluminum between the die and the liner, a positive clamping force is applied to seal the container against the die. This force is greatly augmented at the beginning of extrusion by the force of the press. This is due to a good percentage of the press tonnage being transmitted into the container due to friction of the billet against the liner bore. This force diminishes as the billet is extruded until a point is reached whereby a reverse force is actually induced into the liner. One would think that it would be easy to calculate the force of the liner on the die and allow for sufficient bearing area. However it is not so simple.

The sealing pressure exerted on the die by the press container shift cylinders is easy to calculate. The additional forces emanating from the press are very difficult if not impossible to determine as they vary with the pressure required to extrude each billet and are constantly diminishing as the ram advances through the container. To reduce or prevent die indentation into the liner face, ideally there should be a minimum of 1 ½ inches of bearing area around the liner. This means that a 7-3/8 inch bore liner should have a 10 3/8 inch die face. In the real world this does not usually happen due to the costs of the larger dies. Most presses with a 7-3/8 liner bore have die faces of only 8-1/2 inches and sometimes even less. This is the reason that the die coins itself into the face of the liner and it must be periodically faced off. When a container is relined a minimum of ¼ inch but no more than ½ inch should be allowed for future facing. In no case should the liner be allowed to become flush with the container.

**Aluminum Build Up on the Face of the Die.** The build up of aluminum on the face of the die will cause flash outs and damage to the face of the container. The internal bore of the liner could also experience

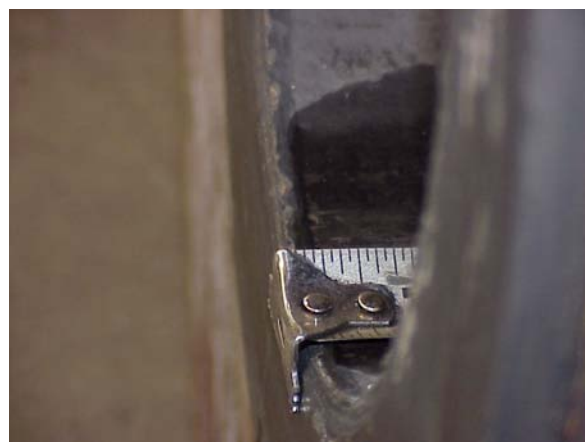

Figure 3-11: Liner with badly coined face, probably due to insufficient contact surface between die and liner face.  
(Photo courtesy of Lake Park Tool)

scoring if the build up is of sufficient thickness and is unevenly distributed around the die to such an extent that it forces the container off centerline. The dies need to be kept clean and free of this buildup. The buildup of aluminum is mainly caused by the butt shear not severing the butt cleanly off the die. This can be the fault of the shear in that its design is not conducive to clean shearing. Another contributing factor to aluminum buildup is the fact that in most presses the die tooling is not held in position securely enough to prevent moving during shearing. Spraying the face of the die is one remedy but not a cure. A more long term solution is to install a butt shear that has a well guided blade carrier and a sharp cutting angle on the shear blade itself. For the shear to operate most efficiently a positive die hold-down that is hydraulically activated is required. This device will hold the die tooling securely in place during shearing.

**Caved Pressure Ring and/or Caved Platen Seat Behind the Ring.** If the die support ring in the platen or the platen itself is dished or caved in, this will cause the container to move off centerline and cause the same problems as die build up. This condition will also cause numerous die problems, however this subject is not part of this presentation.

**Inspection before relining.** When a container does need to be relined, a thorough inspection of the unit in your plant could save you the cost of shipping a heavy piece of scrap to a reline shop. If the container has extensive cracks in the keyways or in lift holes or in thermocouple holes or is annealed and bowed, it is probably not worth relining. New containers made from 4340 forged steel are heat treated to 34-38 Rockwell "C" scale. If H-13 is used for the container they are heat treated to 38-42 Rockwell "C". The liners are mostly made from H-13 and are heat treated to 44-48 Rockwell "C". If A-286 or Inco alloys are used for the liners they are solution aged to 40-44 Rockwell "C".

In summary there are a number of corrective measures that can be taken to get the most life possible out of your containers and liners. Understanding the cause of the problems will allow you to take the proper corrective measures that will extend the life of your container/liner assemblies.



## Container Life and Relining Frequency<sup>18</sup>

“The mantle and sub-liner are under repetitive mechanical stress and thermal stress, and accordingly the materials eventually start to degrade. Therefore, extrusion conditions, notably pressure and temperature, dictate life expectancy of the container body and sub-liner. Typically, bodies (mantles) are expected to perform at least 5 to 10 years before replacement is necessary. Sub-liners (outer liners) should last at least 5 to 10 years, while a liner generally requires replacement every 12 to 18 months, predominately due to wear.”

## Spare and Replacement Tools

The following recommendations are offered for maintaining spare tools such as container, liner, ram, etc.:

- Maintain accurate drawings of all tools, for purchase or repair of replacement of spares.
- Inspect spare tools when received (new or repaired) for condition and conformance to dimensions.
- Store spare tools in a warm place, to minimize preheat time and avoid thermal shock.

## Dies & Back-up Tooling

While not normally considered a part of “press maintenance,” proper care and handling of dies and support tooling are critical to smooth press operation. For example, in plants where the outside dimensions of the tooling stack do not adhere to strict tolerances, excessive maintenance to the butt shear and die changer will result.

Additional information on maintenance of dies and back-up tooling is contained in the following article, “*Preventive Maintenance of Extrusion Tooling*,” by Gary Dion, Nova Tool and Die, Inc.

## Die and Tooling Cleaning

Dies, dummy blocks, and other tooling must periodically be cleaned of aluminum build up.

“The use of sodium hydroxide for die cleaning, rather than employing emery paper, can result in a decrease in extrusion pressure, permit lower temperatures, higher speeds, and less metal pickup, partly because of their superior finish on bearing surfaces. Solutions of 10% to 25% are customary. When tanks are employed, “standard” solutions are the rule, but a higher concentration is necessary if wiped on. Tank solutions are heated to about 140°F (60°C). Thorough rinsing is necessary following cleaning to guard against caustic effects on the aluminum. Precautions against excessive breathing of fumes as well as direct contact with the skin, particularly the eyes, should be taken. Potassium hydroxide also is used for cleaning but the cost may be prohibitive. Cleaning caustics may stain extrusions<sup>19</sup>.”

<sup>18</sup> Chien, Ken; Dixon, Bill; Robbins, Paul; and Jowett, Chris; “The Design and Benefits of a Thermally Stable Container,” *Proceedings of 11th International Aluminum Extrusion Technology Seminar*, (2016), p.427-450.

<sup>19</sup> From “Extrusion Dies and Tooling Manual: Recommended Handling and Maintenance,” AEC (Aluminum Extruders Council), [www.aec.org](http://www.aec.org).

**Notes:** *(this page is intentionally blank)*

*Note: The following paper provides useful information about the inspection, handling, and preventive maintenance of extrusion dies and back-up tooling. It was first presented by the author at the AEC Press Maintenance Seminar, in Chicago, May 2, 1995, and is reprinted here with his permission.*

## PREVENTIVE MAINTENANCE OF EXTRUSION TOOLING

by Gary Dion

Extrusion Consultant (former owner of Nova Tool and Die)

How does preventive maintenance relate to extrusion tooling? From surveying many extruders it was found that proper preventive maintenance of tooling plays a very important role in the success of an extrusion operation. Improper maintenance can and most likely will result in poor performance in one or more of the following areas:

- Pounds per hour of aluminum produced
- Extrusion die life
- Die and support tooling breakage
- Press downtime which is very expensive
- Maximizing die life while minimizing weight per foot

Even though with dies you don't check the oil level, inspect roller bearings, or monitor wear of motor brushes, there are many aspects of the extrusion tooling to be checked and maintained properly. As the Fram oil filter man says, "You can pay me now, or pay me later," and in some cases a whole lot more! The possible checks and maintenance steps for extrusion tooling can be broken into four major categories.

- 1) Incoming inspection of dies and tooling
- 2) Handling of dies and tooling
- 3) Inspection of dies and tooling after use
- 4) External features of dies and tooling

### **Incoming Inspection**

It is not good manufacturing practice to put a bad die in the press and waste valuable press time, labor, billet, etc. Of course this probably doesn't happen, at least not very often. But what are you currently monitoring to maximize your presses' productivity? Could you be monitoring more? Listed below are many of the checks extruders have implemented to achieve the highest quality product at the most productive rate.

**1) Proper tooling identification.** Die, suffix, backer, bolster and feeder plate numbers are important. If the wrong number is on the die, it could be set up and run incorrectly, causing major problems. Also, date and vendor ID are a good idea.

**2) Check for metal chips or shavings from manufacturing.** These tiny metal shavings will hide in the relief area or bearing area of the die and show up in the extruded product or possibly create die lines.

**3) Check die and related tooling for proper Rockwell.** Even though most die makers thoroughly inspect for this, it's not impossible to vary by a few Rockwell C points.

**4) Tool diameter, thickness and step dimensions.** It's better to be safe than sorry. Checking tool dimensions will prevent tools from being stuck in die rings, or being loose, allowing for misalignment and/or aluminum seepage into undesired space, butt shear from hitting the tooling face, etc.

**5) Pinout of die openings.** This will tell you how much tool deflection you are getting on your tooling, which is extremely useful for future dies. It will give accurate information for zeroing in on minimum weight per foot, allowing for maximum poundage from each die.

**6) Support tooling clearance.** Check for interference of backers, bolsters, sub-bolsters and platen opening. It is better to grind in some clearance which will decrease the possibility of plugging and/or possibly breaking the assembly.

**7) Proper support on backer, bolster.** Make certain that the backer and bolster have the proper support to eliminate as much tool deflection as possible, and minimize the chance of tool breakage.

**8) Proper exit clearance.** Check the step behind the bearing for proper clearance. There should be a minimum step on critical tongues, screwbosses, etc. Too much clearance can cause a die to cave and run incorrectly. Approximately 0.040" (0.10mm) is considered normal.

**9) Proper die support.** On tongues it is desired to have maximum support for best results. Zero degrees of back taper is usually desired on areas with small or long tongues and screw bosses.

**10) Bearing finish.** Check die bearings for:

- Wire EDM lines
- Scratches from files, gage pins, or emery paper
- EDM pits
- Nicks from handling, shipping
- Burrs on exit side of bearing from orbital EDM or milling relief

It would be better to catch one of these items and correct it prior to sampling or attempting to run the order. How many times have you pulled a die because of die lines?

**11) Bearing flatness, squareness.** Not enough can be said for the importance of square and flat bearings. A precision square needs to be used to confirm that the bearings on both the die and mandrel are flat and square.

**12) Bearing transitions.** Proper placement and smoothness of bearing transitions are critical as this is another area which can cause die lines. Improper placement of transitions will also cause the die to produce a product that is not dimensionally correct.

**13) Maximum port/spreader/feeder plate openings.** These items if made too close to the container opening will cause poor metal finish. Contamination will enter the ports from the skin of the billet and be extruded into the profile. Poor metal quality will also result if the profiles are too close to the container size on a solid die.

**14) Proper die alignment and handling features.** Inspect dowel pins, keyways, bolster pins, etc., for proper position and sizes.

## **Handling of Tooling**

Dies and tooling are the heart of your finished product. Bad dies, bad extrusions. It's that simple. Dies should be treated like jewelry, not blacksmith anvils. This slight exaggeration was not meant to insult the die handlers but to stress a point. Too often dies are not treated with enough care and are damaged due to carelessness. Make every attempt to keep dies off the floor as dirt in the tools will result in poor metal finishes. Care must be taken when removing assemblies from the die rings. A die separator would be recommended rather than a big hammer, even if the hammer is aluminum. Too many tongues, screwbosses, etc., have been lost to the blow of a hammer. Careless banging of tooling together can damage bearing surfaces and mating surfaces.

## Inspection of Tooling After Use

After the tools are used to extrude the required product and have been run through caustic, a careful inspection of all components is recommended. Putting a damaged tool in production is obviously not a desirable practice. Here are a few areas to check for:

### ***All Dies:***

After each extrusion run, all dies should be inspected for the following conditions:

- 1) **Wash-out on bearing surface.** Washed out bearings can cause poor metal finish. Polishing the wash-out from the bearing will eventually cause an overweight condition. It might be time to consider ordering a backup die for stock or future orders.
- 2) **Cracks on tongues and critical areas.** Breakage is on the horizon. This can waste valuable press production time.
- 3) **Weight per foot.** Monitoring this factor will prevent you from giving extra metal to your customers.

### ***Hollow Dies:***

Hollow dies should be inspected after each run for the following conditions:

- 1) **Check for cracked webs, armpits or weld chambers on the housing.** Some hairline cracks are normal, but excessive cracks will lead to complete tool failure.
- 2) **Flatness of housing face, die face.** A caved entry is a sign of tool fatigue and replacement might be considered. This can cause die and mandrel bearings to be misaligned resulting in poor metal quality.
- 3) **Rockwell hardness of tool components.** Low Rockwell hardness of dies can cause poor metal quality and tool failure. Recommended Rockwell C is usually 47-49. Sometimes tools can be re-heat-treated to avoid premature failure.
- 4) **Tapered sealing area on die and spider assemblies.** Check for nicks on the outside taper which could damage the die ring.

### ***Solid Dies:***

Solid dies should be inspected after each run for the following conditions:

- 1) **Flatness of die, backer.** If the die or backer isn't flat, more than likely the metal isn't hitting the bearing surface correctly and you are losing control of the metal flow. It also is allowing the die to deflect too much which contributes to poor production and bad material. Caved tooling could be a sign of improper or cracked support tooling (backers, bolsters).
- 2) **Cracked corners on die openings.** This could result in burrs or die lines on the extruded product. This also could be a sign of poor or cracked support tooling.
- 3) **Cracked backers.** Cracks in backers will cause metal to run poorly and can result in premature failure of dies.

### ***Bolsters and Support Tooling:***

Support tooling should be inspected on a regular basis rather than only when a profile runs poorly. Check for the following conditions:

- 1) **Flatness.** Bolsters and sub-bolsters which are not flat will cause problems when extruding. This will allow for the die to deflect too much. It is also extremely important when running wide profiles or profiles with critical tongue conditions. Many times bolsters, etc., can be reground flat and even re-hardened if necessary.
- 2) **All surfaces clean and free of aluminum build up.**
- 3) **Rockwell.** Periodically check the Rockwell to insure the tool isn't being annealed over time being exposed to temperature changes. The ideal Rockwell is between 42 and 46 RC.

**4) Inspect for cracks.** Small cracks in the corners eventually become big cracks, which could cause the whole tool stack to fail, including the die and backer. Replacement should be considered soon.

**5) Nitrogen Inlets.** N<sub>2</sub> couplings and inlets must be kept clean to allow free flowing of liquid or gas nitrogen. Also, this prevents dirt from passing through to the metal.

**6) Nicks.** Check for nicks caused by handling the tooling. It's easy to bang these large tools into other pieces of steel or tooling. Nicks will keep other tooling from sitting flat and could cause damage.

**7) Lift holes.** Make sure threaded lift holes are free from foreign materials which could prevent the eye-bolt from being threaded in completely. This decreases the chance for accidentally dropping the bolster, thus damaging the tool and even possibly injuring someone.

### ***Platen Pressure Ring:***

As true with other support tooling the platen pressure ring needs to be inspected periodically. Check the following items:

**1) Flatness.** Check for an impression approximately the size of the bolster or sub-bolster. This means the ring is wearing and needs to be considered for replacement.

**2) Clean.** Free from aluminum build-up.

**3) Cracks.** If the pressure ring is cracked you can be assured the whole tool stack is deflecting which will eventually cause other tooling components to fail.

### ***Die Rings:***

The ring which contains the die assemblies also needs to be regularly maintained:

**1) Sealing areas on tapered die rings.** The tapered area on die rings which hold spider assemblies must be kept free of nicks and aluminum build-up. It is also important to monitor the sealing area for impressions from the assembly. This could be an indication that the spider assembly is improperly sized. This will also allow unwanted aluminum to build up between the ring and assembly.

**2) Sealing areas on step die rings.** Again check for metal build up. Inspect for chips of the ring missing which could allow aluminum to squeeze between the ring and die components resulting in difficulty to disassemble. Check the step dimension to insure that the die doesn't protrude too far, allowing the butt shear to hit the die. This could also cause the die to leave an impression on the container liner which could cause flashing.

**3) Lift holes.** Make sure threaded lift holes are free from foreign materials which could prevent the eye-bolt from being threaded in completely. This decreases the chance of dropping the assembly, damaging the tools and even possibly injuring someone.

**4) Keyways.** Worn keys can cause misalignment of the die and backer assembly. This could result in clearances not being correct and plugging of the tool. Replace the keyways periodically for maximum reliability.

**5) Nitrogen hookups.** If gas or liquid N<sub>2</sub> is introduced through the die ring make sure hookups and inlets are in proper working condition, clear and free from buildup. Check sealing area for damage or wear.

### ***Die Carriers, Die Slides:***

Over the course of multiple die changes the die slide is prone to wear and tear. Proper inspection and upkeep will help keep the dies in their proper position during the extrusion process, and keep the die and ring from being damaged by the shear. Routinely check for the following items:

**1) ID of horseshoe.** Check for proper fit to die rings.

**2) Build up of grease, dirt, or aluminum.** This will cause improper alignment of tooling.

**3) Horseshoe bolts.** Assure tightness of these bolts periodically.



### **Other steps to take for optimizing press and tooling performance**

Organization of dies and support tooling with easy access will help prevent the wrong support tool from being used. Location numbers can even be used to organize the tools.

Once the die, whether it be a hollow or a solid, is cleaned, inspected and ready for storage, it is recommended that the internal areas of the die be coated for protection from rust, dirt, etc. These areas would be die bearings, pockets, ports, etc. On some complex profiles some extruders even leave the die full of aluminum if the die performed well on the last run. One of the more popular coatings is an aluminum spray which doesn't affect the metal on the next run.

A good high temperature anti-seize compound should be applied to all bolts used in the die assemblies. Anti-seize also should be used on replaceable parts such as pincores and mandrels which fit into pockets. This will help during the replacement process.

If you have more than one press in which a die assembly can be used, it is important that care is taken when making tool stack setups. Make sure the proper bolster, sub-bolster, spacer rings, etc., are used to make up the proper tool stack. It's easy to miss the proper thickness and plug the first billet, creating unwanted downtime. Also check for proper clearances all the way through the tool stack.

Press alignment plays an important role in the production and quality of metal. There are various means of checking press alignment, and it should be checked and corrected weekly.

Developing a re-nitriding program will help maximize die life and press productivity. Through such a program one should be able to accurately predict the amount of billets to run of a certain section, rather than waiting for a die line or something to show up on the metal. Excessive tool wear and bearing washout can be reduced through proper monitoring.

On hard pushing dies the practice of using a short, and sometimes hotter billet is recommended to start the die on the first billet. This will reduce the risk of damaging the die.

Insuring that dies and support tooling are preheated properly is of critical importance. Cold bolsters and other support tooling can crack during use, and can also draw too much heat out of the die assembly.

### **Summary**

Although some of the items covered in this article might seem a little elementary, it is important to make sure as much prevention is considered with extrusion tooling as possible. Anytime a problem or potential problem is detected before trying to extrude, you can save valuable press time, and even prevent major tool failure.

**Gary Dion**

## Minimizing the Occurrence of Flared Billets in Aluminum Extrusion Presses

A common problem of aluminum extrusion is flared or mushroomed billets --- in which the aluminum spreads out between container and die instead of passing through the extrusion die. Flared billets result in lost production time and also scrap. Occurrence of more than one or two flares per month is considered excessive.

Mr. Domenico Bertoli of SEPAL, a well known extrusion expert, has recommended steps which can be taken to reduce the occurrence of flared billets:

1. The sealing surface between container and die/die ring must be clean and smooth. The butt shear blade must be in good condition and designed for a smooth, clean cut. Clearance must be adjusted properly, typically 0.020 inches (0.5 mm) for smaller presses, up to 0.125 inches (3.2mm) on larger presses<sup>20</sup>. Proper release agents sprayed automatically on the shear blade will also help<sup>21</sup>.
2. It is also important to maintain the correct specific sealing pressure on the surface between container and die/die ring. Specific pressure is defined as the sealing force divided by the contact surface area. The minimum value desired<sup>22</sup> is **2.5 kg/mm<sup>2</sup>**, which converts to **3,550 pounds per square inch**.

To compute the specific sealing pressure:

- **Calculate the sealing force.** For each sealing cylinder, the effective area is the area of the bore minus the area of the rod<sup>23</sup>. Multiply this net area by the sealing pressure and by the number of sealing cylinders (typically two, occasionally 4). The result is the sealing force.
- **Calculate the area of the contact surface.** This area is the difference between two circles. The smaller circle is the container inside diameter, which is usually about 0.375 inches (9mm) larger than the nominal billet diameter. The larger circle varies with containers but should be the outside diameter (OD) of the container liner, assuming that the liner extends slightly outside the container forging as it should. Subtract the smaller area from the larger to determine the contact area.
- **Divide the force by the area.** Divide the sealing force by the sealing area to determine the sealing specific pressure.

If the specific sealing pressure is too low, indicating poor sealing, there are two ways to increase it:

1. **Increase sealing pressure.** This is subject to the capabilities of the hydraulic system and the pressure ratings of the hydraulic cylinders and piping. Do not exceed capacity of cylinders.

<sup>20</sup> Follow press manufacturer's recommendations.

<sup>21</sup> For additional information contact Amcol Corporation, 21435 Dequindre, Hazel Park MI, tel 248-414-5700, fax 248-414-7489, [www.amcolcorp.com](http://www.amcolcorp.com).

<sup>22</sup> Mr. Alan Castle of Service Aluminium recommends values up to twice this value, but cautions that the contact area between liner and die must bear additional force during the early part of extrusion, when the friction force is added to the sealing pressure. He cautions to be sure that the contact area is not reduced so much that it will cause the die to deflect unduly; he especially advises that the liner not contact the die ring, which is usually unsupported and so may deflect too much under this force.

<sup>23</sup> For presses with platen-mounted sealing cylinders. A few presses such as "front-loading" presses, have direct-acting cylinders, mounted on the main cylinder, in which case the rod area is not deducted.

2. **Reduce the contact area.** Since the inside diameter of the container liner should not be changed, the outside diameter may be reduced. First calculate the desired outside diameter, based on the area needed to give the correct specific pressure. Then at that diameter introduce a slight ( $7^\circ$ ) bevel at that point to limit the contact surface. (See illustration.)

**Sample Calculations:**

Sealing force: assume 2 cylinders, 9" bore x 6" rod, 2500 psi

$$\text{Area} = \pi d^2/4$$

$$\text{Total area} = \pi 9^2/4 = (3.14159)(81)/4 = 63.62 \text{ in}^2$$

$$\text{Minus rod area} = \pi 6^2/4 = (3.14159)(36)/4 = 28.27 \text{ in}^2$$

$$\text{Effective area} = (63.62 - 28.27) \times 2 \text{ rods} = 35.35 \text{ in}^2 \times 2$$

$$\text{Force} = 2500 \text{ psi} \times 70.70 \text{ in}^2 = 176,750 \text{ pounds}$$

Contact area: container ID 8.375", liner OD = 12.5"

$$\text{Total area} = \pi 12.5^2/4 = (3.14159)(156.25)/4 = 122.72 \text{ in}^2$$

$$\text{Minus ID area} = \pi (8.375)^2/4 = (3.14159)(70.14)/4 = 55.09 \text{ in}^2$$

$$\text{Effective area} = 122.72 - 55.09 = 67.63 \text{ in}^2$$

Specific pressure: Force/area =  $176,750/67.63 \text{ in}^2 = 2613 \text{ psi}$  (too low)

To calculate a suitable sealing area:

Assume no change in sealing force = 176,750 pounds

$$\text{Desired area} = 176,750 \div 3550 \text{ psi} = 49.79 \text{ in}^2$$

$$\text{Plus area of liner ID} = 55.09 + 49.79 = 104.88 \text{ in}^2$$

$$\text{Using Area} = \pi d^2/4 = 104.88 \text{ in}^2$$

$$d^2 = 104.88 \times 4/\pi = 133.54$$

$$d = 11.56 \text{ inches}$$

Therefore, mark the face of the container liner at 11.56" and bevel the face outside that point. (See Illustration)

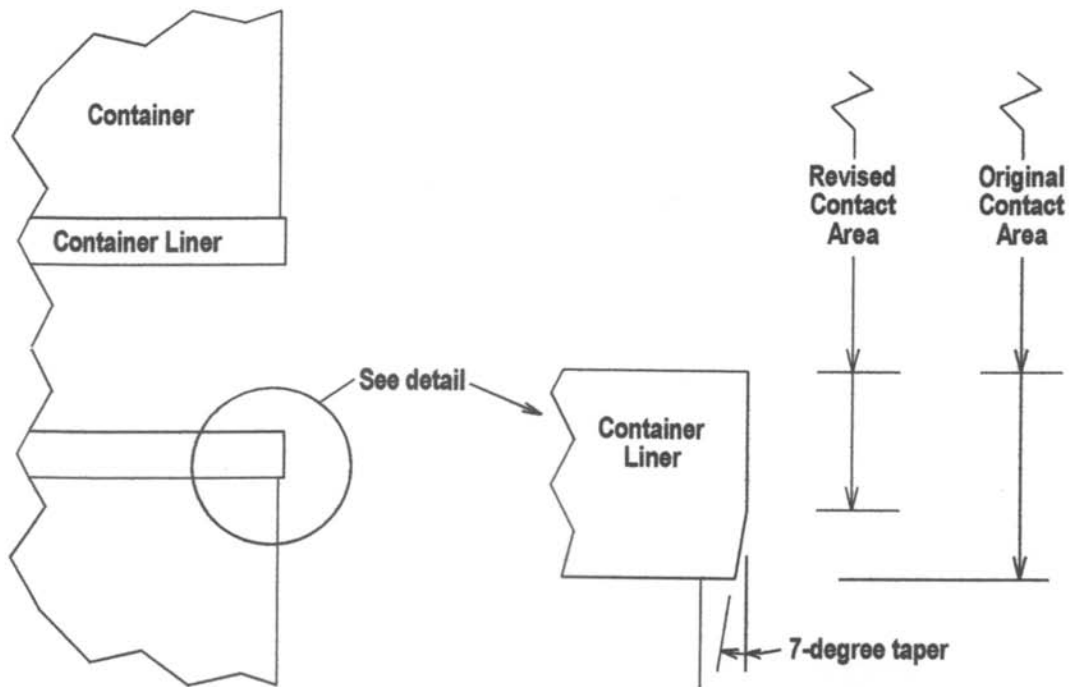
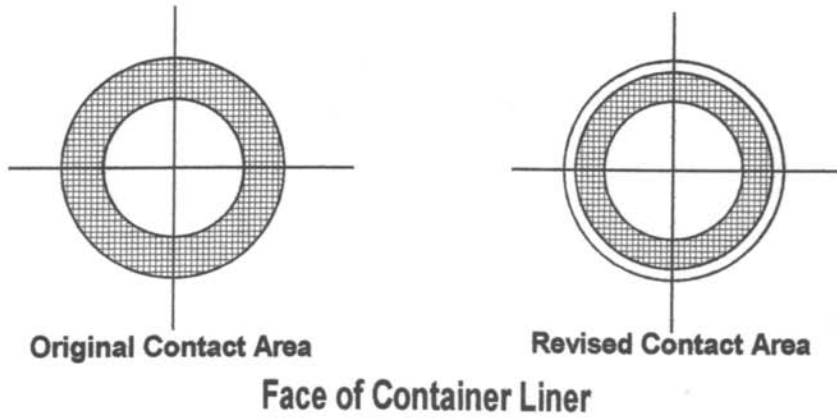

## REVISED CONTACT AREA BETWEEN DIE AND CONTAINER LINER

## Press Tool Lubrication Systems

By James E. Dyla, President, AMCOL Corporation

### General Overview

Lubricants are used in the extrusion process to eliminate build up and sticking of hot aluminum to extrusion press tools. Many years ago, these lubricants were manually dispensed using solvent carried graphite greases that were randomly applied on an as needed basis. Today, automatic dispensing systems are strategically located to lubricate some of the following areas:

- Hot Log Shear
- Billet and/or Dummy Block
- Butt Discard Shear

On older extrusion equipment, automatic spray systems are most often retrofitted to the press. Newer presses most often include automatic lubrication.



### Types of Lubrication Systems

Three basic system designs are used to automatically lubricate press tools. Included are the following:

System Description	Lubricant Type	Primary Applications	Secondary Applications
Electrostatic Powder	Boron Nitride (BN) Powder	Billet End	None
Pressurized Liquid with Air Atomizing Nozzles	Water Based Polymer Liquids	Billet End, Dummy Block, Butt Shear, Log Shear	Die and/or Container Seal Rings, Billet Scalper Tooling
Positive Displacement Injection Metering	Synthetic Neat Oils and Water Diluted Lubes	Log Shear, Butt Shear	Primary Application is on Saws – See Chapter 8.

System design, installation, and maintenance help to maximize uptime and minimize associated mess.

### Electrostatic Booron Nitride Powder for Billet End Lubrication

Understanding that BN is hygroscopic is very important; this means that BN will attract water from the air then agglomerate and form larger clumps. This can occur in the shipping container or in the hopper (also known as the reservoir). Once BN becomes wet, it will not hold a charge. BN is lightweight, so the dust can float throughout the press area causing machine contamination issues and a slip/fall safety hazard. BN can also become very expensive with overuse.

Primary components for electrostatic spray include:

1. Hopper – A reservoir or container that protects the powder from the elements. Most importantly, the hopper limits exposure to humidity in the air.
2. Powder Mixing and Drying
  - a. Auger with Air Blanket – Older designs incorporate a rotating paddle mechanism inside the hopper that operates like a bread mixer. This type of hopper has an air blanket over the top to dry the powder. In certain extreme

humidity cases, a heat lamp is placed over the powder. The auger mechanism can inadvertently pack the powder as it is mixed.

- b. Fluidizing Bed – More common today, is the use of a honeycomb block that is placed below the powder to infuse the powder with air as it is bubbled up through the powder. The fluidizing bed process continuously dries and fluffs the powder for better consistency and density. Fluidizing air is exhausted from the top of the hopper which allows for a continuous drying of the powder using dry plant air. Be sure that system service air is completely dry when using the fluidized bed process. An in-line desiccant is recommended to monitor air quality where a color change of the desiccant indicates the presence of water in service air.



3. Injector – Air is used to venturi vacuum the powder from the hopper.
4. Controller – Many variations of the electronic controller are used to set air flow, charge transfer voltage, and other adjustments. Older controllers have manual adjustments for each control detail. Modern controllers are 100% electronic and can even include recipe driven settings specific to the powder being dispensed. Keep in mind that tap density and particle distribution for powders from different suppliers may vary; as such, controller settings will change based on the powder characteristics.
5. Spray Gun – The spray gun has three functions. First, the spray gun charges the powder as it passes through the gun. Second, a wire tip at the end of the spray gun creates the electrostatic field between the gun and the billet; be sure this wire is in good condition for proper charge transfer. Third, a small nylon tip shapes the spray to a round uniform pattern; this tip is most often damaged from heat or contact with the billet and should be inspected and replaced as necessary.
6. Grounding – The controller has a ground connection that is linked to any components associated with the spray system. More importantly, the billet is somehow connected to this grounding network. No system is perfect for grounding the billet, however the most common systems incorporate some type of chain or wire brush assemblies that are flexible and self-cleaning as the billet passes. Keep in mind that the billet must always be the closest grounded item to the gun to avoid charge transfer and spray directed to something other than the billet.
7. Dust Collection and Vacuuming - Many system variations are used in an attempt to contain dust and overspray. Ironically, the simplest tubular design strategically located just past the spray point can provide the most effective collection of the dust.

A 550 CFM vacuum will suffice when connected to a 4" collection tube. Using a self-cleaning shakedown type filter can insure years of maintenance free operation.

**Best Practices for Electrostatic BN**

- Most importantly, eliminate all sources of water and humidity. Air in contact with the powder must be clean and dry. Nitrogen can be substituted where dry air is not available. An in-line desiccant air dryer is used for monitoring only and should not be used as your primary dryer.
- Ensure proper grounding and charge transfer from the gun to the billet. Distance from the gun to the billet is key.
- Always incorporate powder collection. The vacuum should be designed with a self-cleaning shakedown filter that can automatically clean the air filter after each billet or at the end of each shift.
- Avoid packing the powder. Transfer the powder in small volumes. Fluidizing bed type hopper can mix and dry the powder as opposed to the auger type that can actually pack the powder.
- The powder hose should be as short as possible from the injector to the gun. It should also be down hill without kinks or bends.
- Disassemble and clean the injector, powder hose, and electrostatic gun on a regular basis.



**Recommended Preventive Maintenance for Electrostatic Spray**

- Observe System Settings – Daily
- Observe Powder in Hopper – Daily
- Clean Powder Injector – Weekly
- Empty, Clean, and Refill Hopper – Bi-annually
- Replace Powder Injector – Annually

**Troubleshooting Electrostatic BN Spray Systems**

Problem	Cause and Possible Solutions
No Powder	<ul style="list-style-type: none"> <li>➤ No powder in hopper – Fill.</li> <li>➤ Injector, gun, or hose clogged or malfunctioning – Disassemble, clean, and repair.</li> </ul>
Excessive Powder	<ul style="list-style-type: none"> <li>➤ Feed rate set too high – Lower.</li> </ul>
Excessive Overspray	<ul style="list-style-type: none"> <li>➤ Atomizing air set too high – Lower.</li> <li>➤ Improper grounding of billet – Correct.</li> <li>➤ Grounding from gun is not to billet – Eliminate all grounded sources between gun and billet.</li> </ul>
Intermittent Powder	<ul style="list-style-type: none"> <li>➤ Powder low in hopper – Fill.</li> <li>➤ Injector, gun, or powder feed hose becoming clogged – disassemble and clean.</li> </ul>



Repeated Clogging	<ul style="list-style-type: none"> <li>➤ Powder wet – Disassemble and clean any components that comes into contact with the powder, then fill hopper with fresh powder.</li> <li>➤ Water or humidity in air source – Correct air source condition, then completely disassemble and clean any component coming into contact with the powder. Fill hopper with fresh powder.</li> </ul>
-------------------	---

### Atomized Spray for Billet End Lubrication and Butt/Log Shears

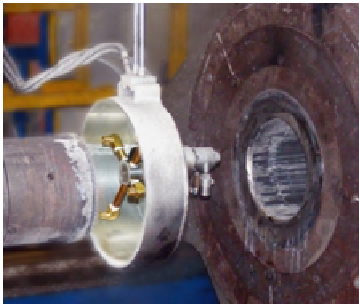

Two basic types of lubricants and release agents are used in this application. Solid film lubricants are for billet ends and dummy blocks where the surface can be easily accessed and properly coated. Liquid film lubricants are used for butt shears and log shears where the tool is often hard to access; liquid lubricants are able to travel by capillary action to create a thin film that completely coats the tool.

#### Primary Components for Pressurized Spray

1. Reservoir – Used to pressurize liquid.
  - a. Pressure Vessel – Typically associated with older designs, a pressure pot is a sealed cannister with pressurized air over the liquid. Pressure vessels are subject to boiler code specifications and testing requirements in many countries. More importantly, simply filling the reservoir require that proper lockout/tagout procedures are followed.
  - b. Non-pressurized Vessel with Diaphragm Pump – This type of reservoir is more commonly used and incorporates an air operated diaphragm pump to generate pressure. With this design, the liquid can be plumbed back to the reservoir for mixing. There is no lockout/tagout requirement for filling. Low level float switches for fluid level monitoring can be easily fitted. Reservoirs are much more accessible for cleaning than the pressure vessel type.
2. Air/Liquid Mixing Valves – Often referred to as the atomizer, this is the air liquid mixing block.
  - a. Piston Style – This type of atomizer can be operated with one air and one liquid connection. The air source used to open this type of valve is the same air used to supply atomizing air. Liquid flow is typically adjusted with a needle valve that is an external attachment to the atomizer.
  - b. Air Pilot Operated – This type of valve is designed to separate atomizing air and the air used to actuate liquid. Cycle times with an air pilot operated atomizer can be quick because the atomizing air can be initiated before the liquid and continue on after the liquid cycle has ended. Liquid flow rate is typically integrated as part of the atomizer with a needle valve. Most





recent designs incorporate a fixed output flow restrictor to insure a repeatable output volume per spray cycle. Air pilot valves are more repeatable than the piston type and allow for a much more effective blow out cycle.

3. Spray Nozzles and Extensions – Most applications in extrusion are hot; often a unique spray pattern is required for each application. Spray tips on rotating unions are used to coat billet ends and dummy blocks for complete and consistent coverage. For shear lubrication, spray extensions from the atomizer to the spray point remotely locate atomizer out of the hot zone.
4. System Controls and Actuation – PLC outputs are used to control 3-way air valves that open and close atomizers. A two-way air pilot operated “safety switch” is also included to shutoff liquid at the controls; this second liquid control is incorporated as a backup to the atomizer shut-off. Air pressure gauges are most often included for system monitoring; use these gauges to monitor the control valve sequencing and valve speed opening and closing.
5. Interconnecting Hose – Use high temperature, wear resistant, hose. Mark and label hose for quick identification.
6. Overspray Containment – Where possible, overspray covers are included to contain and collect spray.



**Typical Schematic for Billet or Block Spray System**

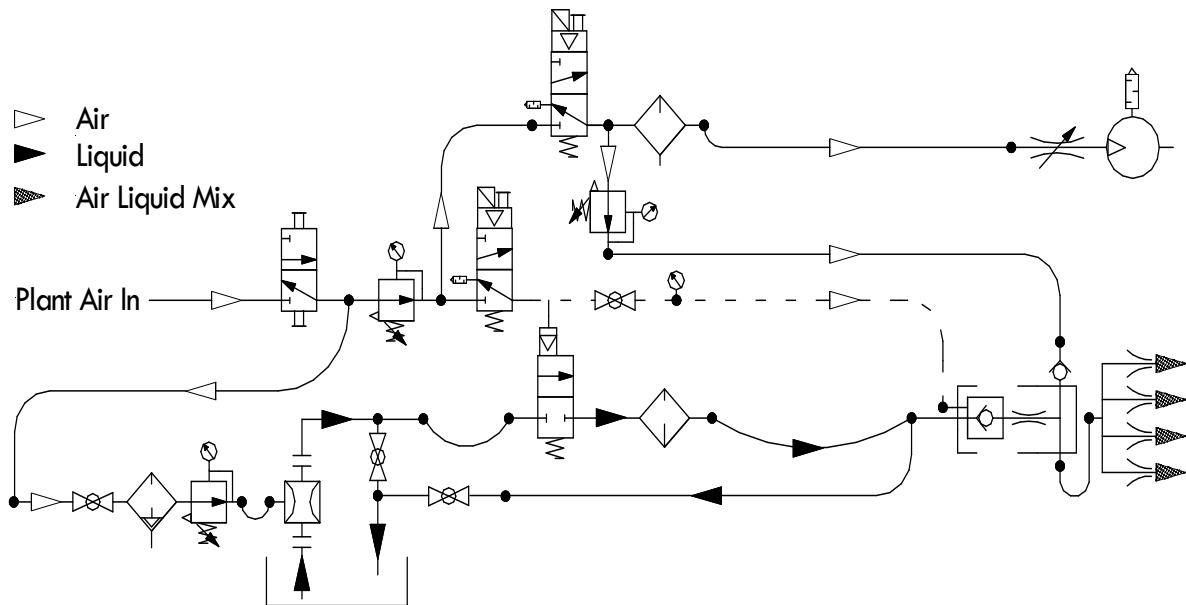

### Typical Schematic for Shear Spray System

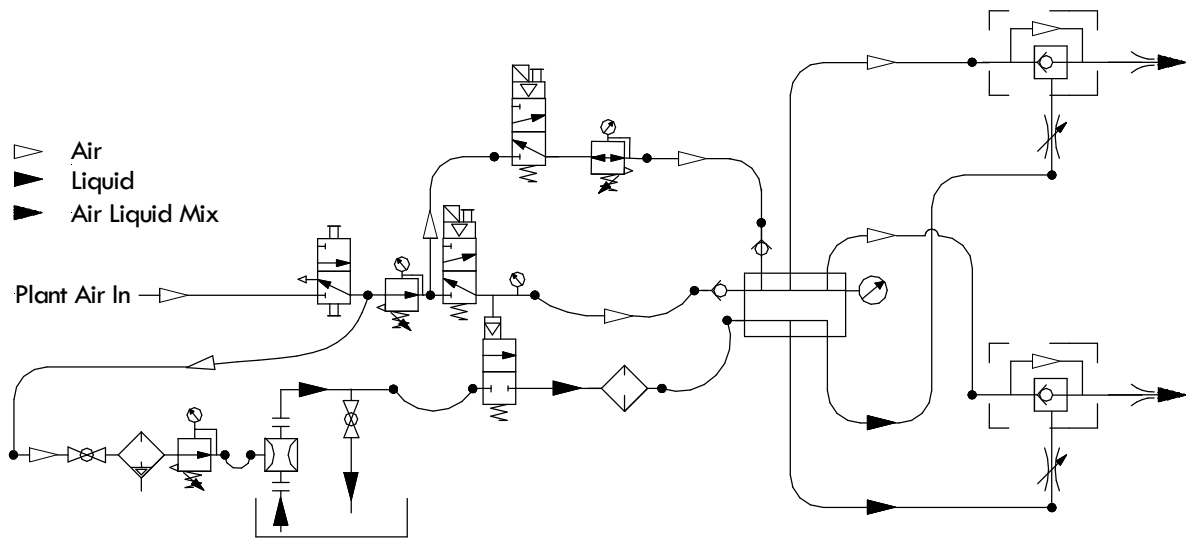

#### Best Practices for Atomized Spray

- Include an air blow out or purge for spray tips and assemblies. Be sure that valve sequencing is properly timed.
- Strategically locate air pressure gauges for system and valve performance monitoring.
- Filter liquid to avoid system clogging and output inconsistency.
- Diaphragm pumps are preferred over pressurized reservoirs.
- Liquid output is typically flow metered. Use liquid pressure to refine output to your exacting requirements. A flow restrictor can eliminate setup error.
- Use stainless steel where practical.
- A rotating nozzle is required for round objects like billets and dummy blocks.
- Use a refractometer to regularly monitor fluid dilution.

#### Recommended Preventive Maintenance for Atomized Spray

- Observe System in Operation – Daily
- Test Fluid Dilution with Refractometer – Daily
- Replace Liquid Strainer – Quarterly
- Check Diaphragm Pump Check Balls – Quarterly
- Replace Atomizers – Biannually
- Replace Diaphragm Pump Check Balls – Yearly
- Empty, Clean, and Refill Reservoir – Yearly

**System Troubleshooting for Atomized Spray**

Problem	Cause and Possible Solutions
No Liquid	<ul style="list-style-type: none"> <li>➤ Atomizer clogged – Disassemble and clean.</li> <li>➤ Atomizer not opening – Clean and/or replace.</li> <li>➤ Liquid pressure too low – Increase.</li> <li>➤ Liquid filter clogged – Replace.</li> </ul>
Too Much Liquid	<ul style="list-style-type: none"> <li>➤ Liquid pressure too high – Lower.</li> </ul>
Too Little Liquid	<ul style="list-style-type: none"> <li>➤ Liquid pressure setting too low – Increase setting.</li> <li>➤ Recirculating valve open too far – Correct to proper setting.</li> <li>➤ Diaphragm pump malfunctioning – Repair.</li> </ul>
Poor Coating	<ul style="list-style-type: none"> <li>➤ Liquid dilution incorrect – Test with refractometer and correct as necessary.</li> </ul>
Fluid Continues Longer than Expected	<ul style="list-style-type: none"> <li>➤ Control valve timing incorrect – Correct.</li> <li>➤ Control valves not properly closing – Repair/replace.</li> <li>➤ Atomizer not properly closing – Repair/replace.</li> </ul>
Liquid is Not Atomized	<ul style="list-style-type: none"> <li>➤ Control valve timing incorrect – Correct.</li> </ul>
Intermittent Liquid	<ul style="list-style-type: none"> <li>➤ Air in liquid line – Purge.</li> <li>➤ Liquid pressure too low – Increase.</li> </ul>

**Compare the Alternatives for Automatic Billet Lubrication**

Electrostatic BN and Water Based Atomized Liquid systems are often compared. A list of strengths and weaknesses follows:

<b>Electrostatic Boron Nitride</b>	<b>Atomized Water Based Polymers</b>
Positives <ul style="list-style-type: none"> <li>• Easy to see coating.</li> <li>• Use as received.</li> <li>• Maximum lubrication.</li> <li>• Dust can be vacuumed.</li> </ul>	Positives <ul style="list-style-type: none"> <li>• Tolerates humidity.</li> <li>• Easy to contain overspray.</li> <li>• Repairs generally low cost.</li> <li>• Reservoir can be remotely located from spray assembly.</li> <li>• Relatively easy to troubleshoot.</li> </ul>
Negatives <ul style="list-style-type: none"> <li>• Does not tolerate water or humidity.</li> <li>• Hard to contain.</li> <li>• Hard to troubleshoot.</li> <li>• Expensive with overuse.</li> <li>• Expensive repairs.</li> <li>• Hopper must be close to spray gun.</li> </ul>	Negatives <ul style="list-style-type: none"> <li>• Coating can be hard to see.</li> <li>• Requires mixing with water.</li> <li>• Limited lubrication properties.</li> <li>• Residue can only be washed.</li> <li>• Build-up in area with overuse.</li> </ul>

## **Precise Injection Metering for Butt Shears and Log Shears**

Injection metering systems are most often associated with saw lubrication. Because they are accurate and reliable, many have chosen to use these systems for butt shear and log shear lubrication. Reference Chapter 8 for more information.

Most importantly, injection metering systems used to lubricate butt shears and log shears require certain design characteristics more specific to the high heat associated with extrusion that are not typically encountered with saws. High temperature PTFE liquid and air hose is recommended. Air/liquid mixing blocks perform best when remotely located and out of the hot zone, rather than mixing air and liquid at the spray point; this type of design should include a blow out function for the spray extensions.

## **Best Practices Common to All Lubrication Systems**

- Eliminate manual adjustments where possible.
- Use clean, dry, and reliable air source.
- Enclose or contain overspray.
- Properly position and safeguard spray nozzles.
- Avoid contamination of lubricants.
- Locate controls and reservoir for access during operation.
- Determine and maintain appropriate system settings.
- Include manual over-ride for system testing and troubleshooting.
- Establish lube transfer/fill procedures and frequencies.
- Establish preventative/predictive maintenance.
- Maintain basic repair inventory.
- Clean spray area and equipment regularly.

**by James E. Dyla, President**

AMCOL Corporation - 21435 Dequindre - Hazel Park MI 48030 - USA

Tel 248.414.5700 - Fax 248.414.7489

jim.dyla@amcolcorp.com - www.amcolcorp.com